

JKS[®]

INSTALLATION INSTRUCTIONS

Product: Steering Stabilizer Relocation Bracket
Part Number: JKSOGS162

Applications: Wrangler JK, 2007+

517-278-1226 • tech@jksmfg.com • www.jksmfg.com
491 W. Garfield Avenue, Coldwater, MI 49036

Welcome

CONGRATULATIONS on purchasing a new Steering Stabilizer Relocation Bracket from JKS Manufacturing. We are committed to providing you with the best products available and your satisfaction is our first priority.

PLEASE READ these Installation Instructions carefully, and save them for future reference, as they contain important installation and maintenance information.

Important

INSTALLATION REQUIRES WELDING by a qualified welder or metal fabricator. Weld-on installation is strongly recommended for maximum strength and reinforcement of the vulnerable factory track bar bracket.

ALTERNATE BOLT-ON INSTALLATION is acceptable on light-duty applications. However, bolt-on installation will not reinforce factory track bar bracket.

NOT COMPATIBLE WITH the OE steering stabilizer. Make sure you have an aftermarket steering stabilizer before attempting installation.

STABILIZER TIE ROD MOUNT PN OGS924 IS REQUIRED on 2010+ models (and recommended on 2007-09 models) in order to install this relocation bracket.

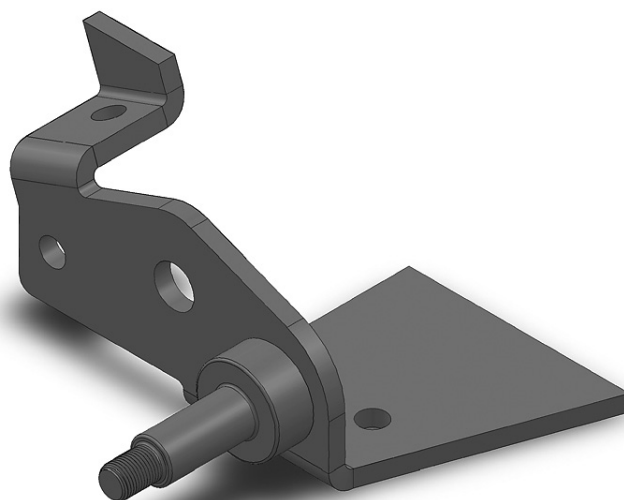

Tools Required

- Hydraulic Floor Jack & Jack Stands
- Metric/Standard Socket Wrench Set
- Black Felt Tip Marker * (or equivalent)
- Torque Wrench
- Die Grinder with Sanding Wheel * (or equivalent tool for removing paint)
- Welding Equipment *
- 3/8" Drill Bit & Center Punch *
- Sharp Metal Scribe *
- Satin Black Spray Paint *
- Plastic Zip Ties or Bungee Cord (recommended)
- Factory Service Manual (recommended)

* Asterisk denotes tools that are not required for some applications. Thoroughly read instructions first to determine which tools will be required for your application.

Parts

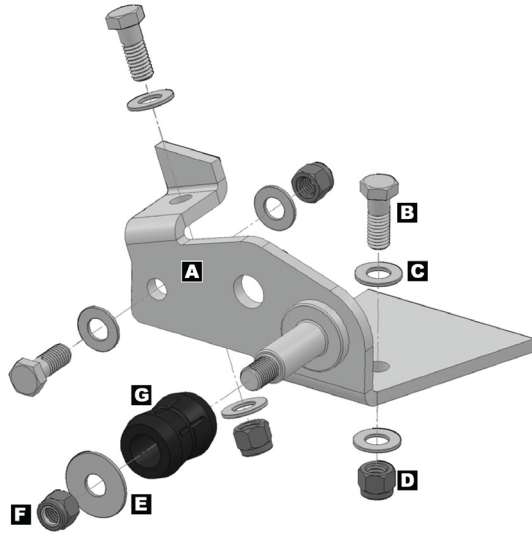

	Description	Part #	QTY
A	Steering Stabilizer Bracket	03032	1
B	3/8" x 1" GR5 Bolt	13105	3
C	3/8" Flat Washer	33082	6
D	3/8" Ovalok Nut	37264	3
E	7/16" Fender Washer	33010	1
F	7/16" Ovalok Nut	37306	1
G	5/8" Poly Hourglass Bushing	M02611-BK-01	1

Installation

❑ 1. DISCONNECT STEERING DAMPER & TRACK BAR

- Raise and support vehicle chassis with jack stands positioned behind the front lower suspension arm brackets.
- Raise and support front axle housing with a hydraulic jack just enough to relieve any tension from the track bar mounting bolts.
- Remove front track bar mounting hardware from axle bracket per the factory service manual instructions for your vehicle. Retain original hardware and temporarily secure axle end of track bar to chassis. **HINT:** Plastic zip ties or bungee cord is useful for securing track bar.
- Remove steering damper mounting hardware from the axle housing and tie rod. Remove steering damper from vehicle and retain original hardware from tie rod end only.

❑ 2. PREPARE FOR INSTALLATION

- To ensure a proper fit, clean any dirt, debris or grease from surface of factory track bar bracket.

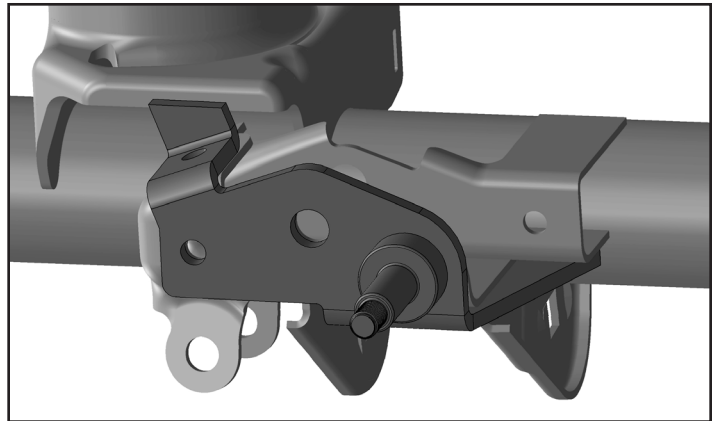

- Position the Relocation Bracket (A) against the factory track bar bracket as illustrated.

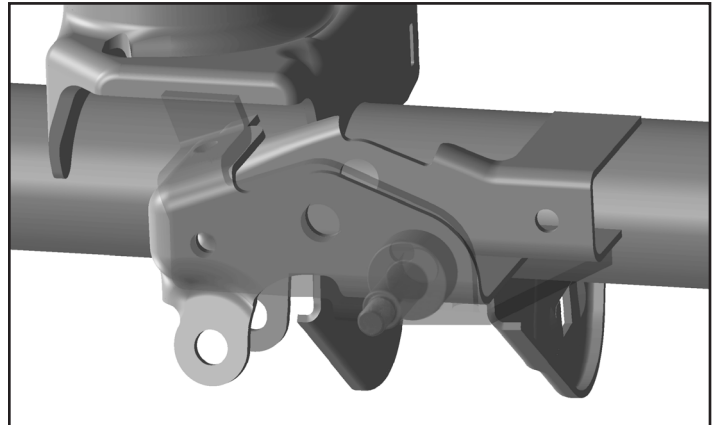

- With the Relocation Bracket (A) in position, insert one 3/8" x 1" GR5 Bolt (B) with Flat Washer (C) into original mounting hole as illustrated below. Secure bolt with another 3/8" Flat Washer (C) and Ovalok Nut (D) and temporarily tighten to hold the bracket securely to the factory axle housing bracket.

HINT: Make sure all mounting holes align with corresponding holes in factory bracket.

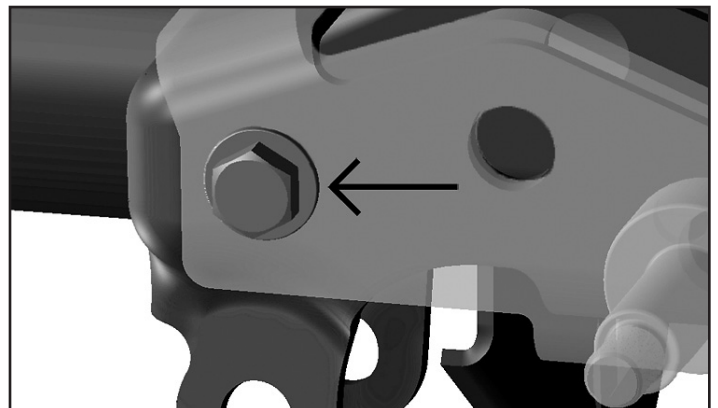

- To prepare for weld-on installation, clearly mark the locations to be welded directly on the axle housing and Relocation Bracket as indicated

below. HINT: A felt tip marker is useful for marking weld locations. This step is not necessary for bolt-on installation.

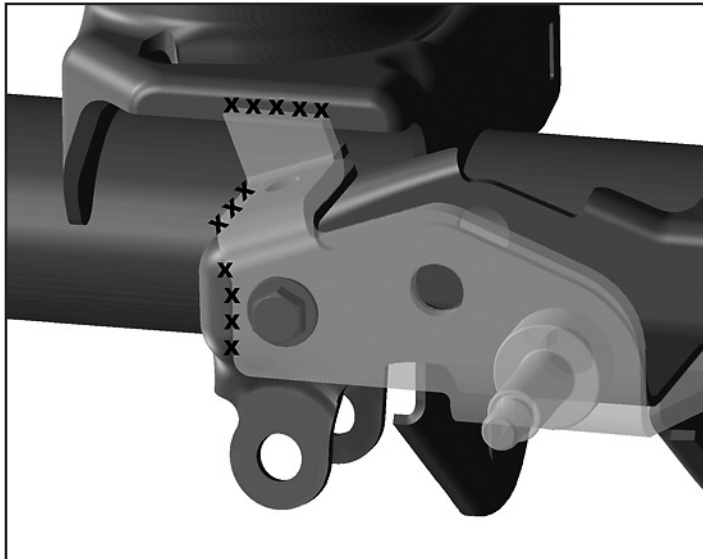

HINT: Be sure to include area on factory coil spring bracket and lower base of Relocation Bracket where it terminates just before it makes contact with axle tube.

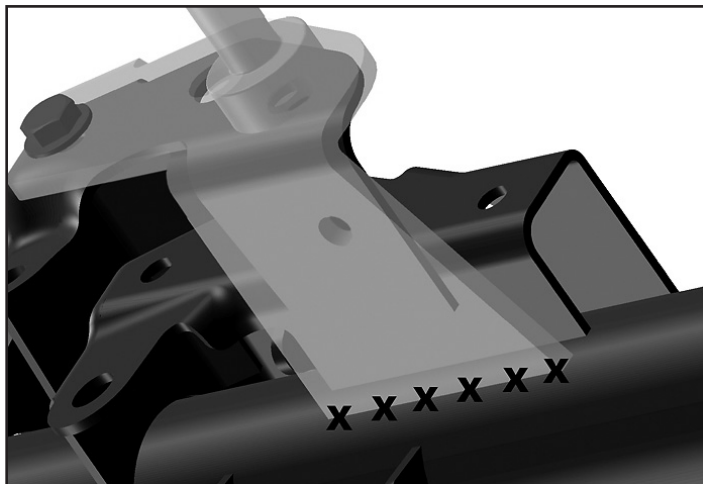

- Using the Relocation Bracket as a guide, mark the exact location of the top and bottom mounting holes on the factory track bar bracket.
HINT: A sharp metal scribe is useful for accurately marking hole locations.
- Remove Relocation Bracket (A) from axle housing.
- To prepare for bolt-on installation, center punch the hole locations previously marked on factory track bar bracket. Then, using a 3/8" drill bit centered on each hole location, drill through the factory bracket. **This step is not necessary for weld-on installation. Proceed to Section 4.**
- To prepare for weld-on installation, thoroughly clean locations on axle housing and Relocation Bracket marked by an "X". Also clean top and bottom mounting hole locations previously marked on the factory track bar bracket.

HINT: A die grinder with sanding wheel or similar tool is useful for removing contaminants.

IMPORTANT: All welding must be performed on bare metal. Remove any coatings, corrosion or other contaminants before welding. This includes removing protective zinc finish (gold) from the locations on the Relocation Bracket that will be welded.

□ 3. WELD RELOCATION BRACKET TO AXLE HOUSING

- With all indicated surfaces prepped for welding, reposition Steering Stabilizer Relocation Bracket (A) on factory track bar bracket.
- Insert the 3/8" x 1" GR5 Bolt (B) with Flat Washer (C) into the smaller front mounting hole in Relocation Bracket.
- Install a 3/8" Flat Washer (C) and Ovalok Nut (D) on bolt to secure bracket in position.
- Using a torque wrench, tighten the 3/8" Ovalok Nut (D) to 40 ft-lbs.
- Tack weld Steering Stabilizer Relocation Bracket (A) to axle in the sequence indicated below.

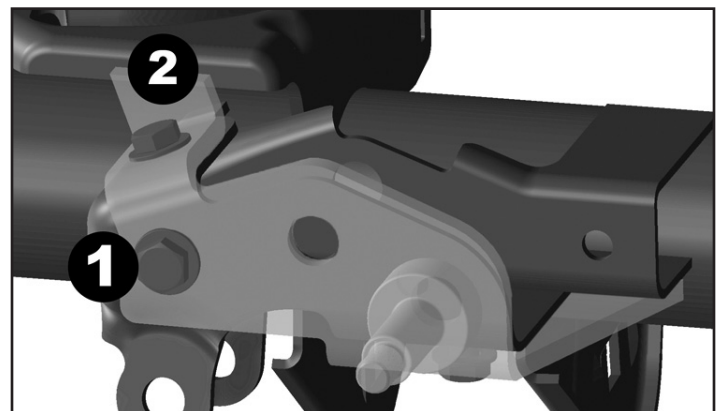

- Tack weld front of Relocation Bracket to factory track bar bracket.
- Tack weld back of Relocation Bracket to factory coil spring mount.
- Tack weld bottom of Relocation Bracket to axle tube. **HINT:** A small gap between Relocation Bracket and axle tube provides clearance for the factory track bar bracket weld. This gap should be filled when making final fillet weld during next step.

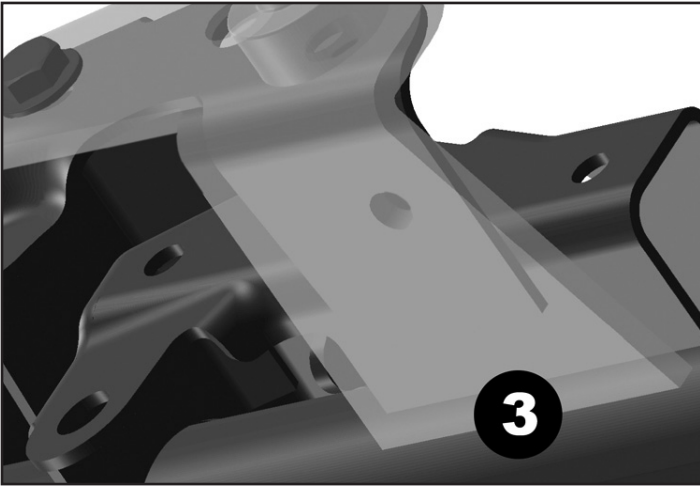

- Next, fillet weld Steering Stabilizer Relocation Bracket (A) to axle housing at all locations indicated by an "X" in step 2.

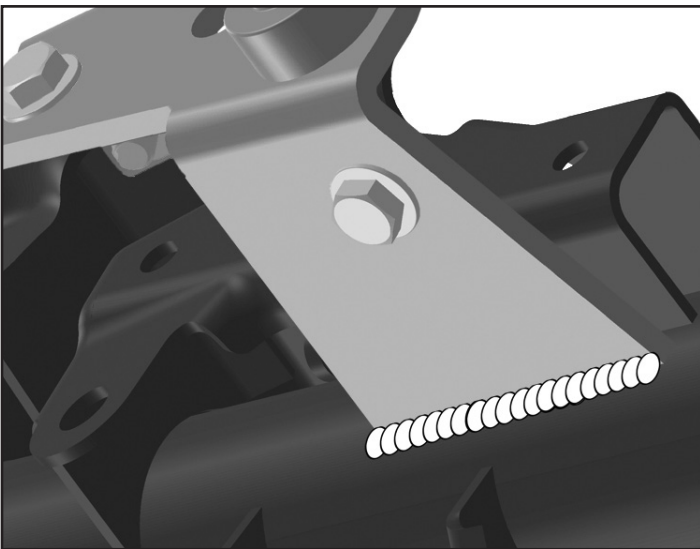
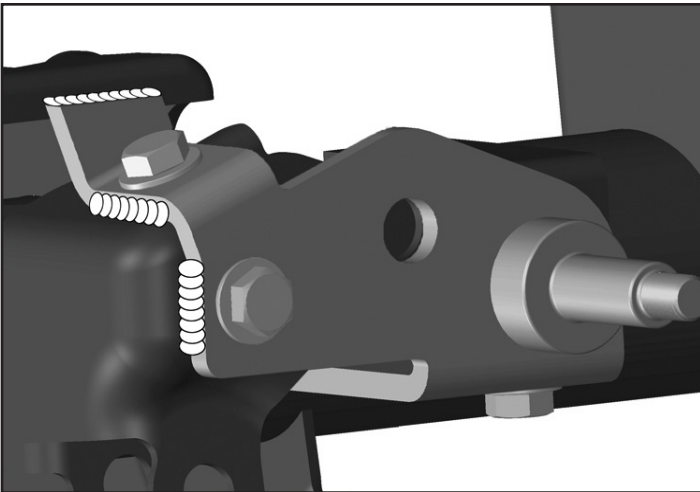

IMPORTANT: Avoid overheating axle tube and factory track bar bracket by welding a small section and allowing the surface to cool off regularly.

- Finally, plug weld Steering Stabilizer Relocation Bracket (A) to factory track bar bracket at

pre-drilled mounting holes on top and bottom of Relocation Bracket.

- Once all welding is complete, spray paint entire Steering Stabilizer Relocation Bracket (A) and any bare metal on axle housing to prevent corrosion. All exposed metal must be completely covered. **HINT: Avoid painting threads of new steering stabilizer mounting stud to ensure proper fitment of supplied nut.**
- Proceed to Section 5.

4. BOLT RELOCATION BRACKET TO AXLE HOUSING

- Reposition Steering Stabilizer Relocation Bracket (A) on factory track bar bracket.
- Insert the three 3/8" x 1" GR5 Bolts (B) with Flat Washers (C) into the corresponding mounting holes in Relocation Bracket.
- Install a 3/8" Flat Washer (C) and Ovalok Nut (D) on each bolt to secure bracket in position.
- Using a torque wrench, tighten each 3/8" Ovalok Nut (D) to 40 ft-lbs.

5. REINSTALL STEERING DAMPER & TRACK BAR

The factory steering damper mounting position on the axle housing will no longer be used. Instead, the damper will mount directly to the stud located on the Relocation Bracket. The bracket will accommodate any aftermarket steering damper designed to fit the JK Wrangler as long as it uses a 5/8" I.D. bushing at the body end. We have supplied a replacement bushing for your damper in case it does not have the correct bushing size.

- Insert axle end of track bar into reinforced axle bracket and loosely install original mounting hardware. Vehicle must be on level ground with coil springs supporting the full vehicle weight before hardware is tightened.
- Using a torque wrench, tighten track bar mounting hardware to 125 ft-lbs.

IMPORTANT: This product is not compatible with the factory steering stabilizer. An aftermarket damper must be installed.

- Mount body end of steering damper onto new mounting stud followed by the supplied 7/16" Fender Washer (E) and 7/16" Ovalok Nut (F).

IMPORTANT: If bushing contains a metal sleeve, remove it to allow fitment. If bushing is too small for mounting stud, replace it with the bushing supplied.

- Tighten Ovalok Nut (F) until the Fender Washer bottoms on the mounting stud.

□ RECOMMENDED UPGRADE

On most 2007-09 models, the shaft end of the steering damper can be reinstalled on the tie rod using the factory bracket. However, we highly recommend our Adjustable Stabilizer Stud PN OGS924 for improved mounting geometry and differential cover clearance – available separately. PN OGS924 is required on all 2010+ models because OE bracket cannot be re-used.

- Remove the U-bolts that secure the factory steering damper bracket to the tie rod and spin the bracket 180 degrees so the mounting stud is located on passenger side of U-bolts.
- Reinstall U-bolts and finger tighten hardware so that factory steering damper bracket can slide freely on tie rod. Determine the appropriate mounting position and tighten the original hardware to factory torque specifications.
- Mount shaft end of steering damper to tie rod using original mounting hardware. Tighten hardware to factory torque specifications.
- If desired, you may remove original mounting tabs from axle housing for improved clearance as they are no longer necessary.

©2013 JKS Manufacturing, Inc & Aftermarketing, LLC
Revision Date 11/1/2013